

# Monitoring large air compressors in a petrochemical plant using APM 360™

Petrochemicals are one of the backbones of modern civilization. The manufacturing processes used to produce them are often complex and rely on well controlled chemical reactions. In this case study, we see how APM 360™ is used to monitor the critical industrial equipment used in the petrochemical industry and provide highly actionable alerts, causes, and recommendations through the use of a hybrid domain-informed AI.

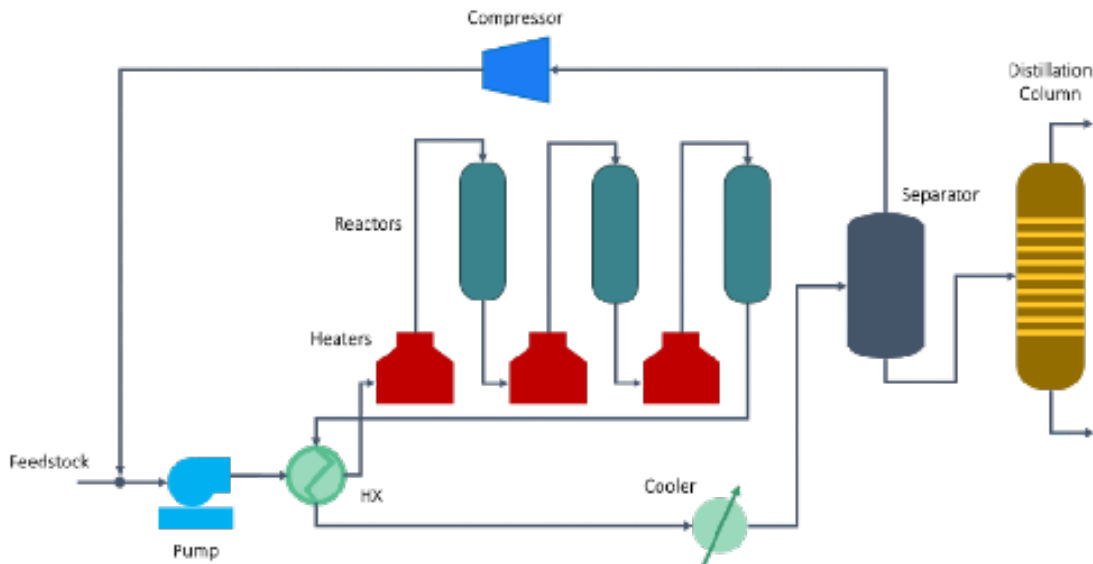

A typical reforming process that is often found in petrochemical plants.

## Problem

Petrochemical manufacturing processes often involve a reforming step. Reforming is the process of altering hydrocarbons to yield the required properties for further processing. Often, this is done with a catalytic reaction between the hydrocarbons, air, and steam. In this use-case, we will see how critical equipment in such a process can be monitored in order to minimize unplanned downtime and ensure smooth and safe operations. A single process outage in a petrochemical plant can lead to several days of downtime resulting in losses of production of over \$1MM.

An example of a commonly used critical asset in petrochemical manufacturing is the process air compressor used to supply compressed air for the reforming process. In this use-case, the compressor is a large, multi-stage, integrally geared centrifugal compressor with a rating of up to 20MW and is driven by a steam turbine.

The particular petrochemical plant referenced in this case study was having outages from time to time but had no reliable way of predicting impending failure of critical equipment. As a result, mitigation of unplanned shutdowns was not always possible and each shutdown event was having a negative impact on the health and longevity of the critical equipment.

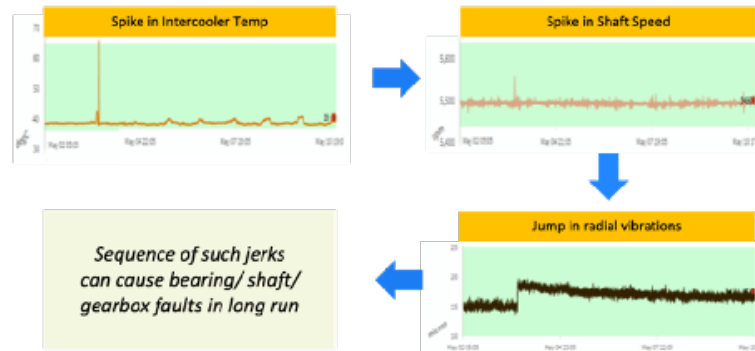

Cooling system anomalies causing jumps in vibration.

**Therefore, an early warning system was desired that could also produce actionable recommendations that would lead to immediate and longer term mitigation of recurrent reliability issues.**

## Solution

APM 360™ was applied at this plant and real-time data from critical equipment was fed into it. APM 360™ uses a blend of process data and asset vibration data to detect incipient anomalies and provide insights into them. It leverages IIOT, AI and FMEA that provide real-time anomaly detection with real-time, automated cause analysis and advisories. This ensures greater reliability, uptime, and peak asset performance due to its ability to predict into the future, analyze leading indicators, and provide causes and mitigation steps immediately.

APM 360™'s anomaly detection system is based on state-of-the-art unsupervised and semi-supervised machine learning algorithms that can identify the key contributing factors for any anomaly detected (e.g. process variables like pressures and temperatures or vibrations). These contributing factors are then fed into a machine reasoning system called the Apparent Cause Engine that can generate one or more apparent causes for the detected anomaly. The machine reasoning engine is based on our proprietary domain-informed FMEA templates that can automatically isolate the underlying cause of an anomaly and give suitable recommendations.

For example, for this particular centrifugal compressor, APM 360™ was able to identify an issue with the cooling water system that led to intermittent spikes in the intercooler temperature. This caused the compressor control system to react by increasing the speed and this further caused sudden jumps in radial vibration levels. Such jumps and jerks on a piece of rotating equipment have adverse long term effects on its health and reliability; however, they are not usually caught by traditional vibration based condition monitoring systems because the vibration levels are still within acceptable vibration limits.

Asset	Time	Cause	Advisory
101-J	May 3, 2019 6:00 PM	• Interstage Cooler Malfunction	• Maintenance Inspect Component

APM 360™ auto-generates causes and recommendations when an anomaly is detected.

But with APM 360™, the blend of process data with vibration data gives a more wholistic view of asset health and how the asset health is impacted by upstream and downstream components of the process. The relationships between a piece of equipment and the process within which it operates is not always straightforward to explicitly model and therefore data-based modelling methods such as machine learning have seen a lot of success.

**Outcomes and Impact:**

- Reduction in unplanned downtime with impact of ~ \$1M / year
- Improvement in efficiency of the compressor

Fault Type	Vibration Monitoring	APM 360™
Bearings	✓	✓
Impeller/Shaft	✓	✓
Gearbox	✓	✓
Seals		✓
Control system		✓
Lube system		✓
Cooling system		✓
Performance		✓
<b>Fault Coverage</b>	<b>~30%</b>	<b>~75%</b>

Significantly expanded component fault coverage using APM 360™ when compared to vibration-based condition monitoring alone.

**However, for automated data analysis systems to be successful in practice, a strong domain knowledge machine reasoning system is necessary to interpret results and convert data into actionable insights, causes, and recommendations.**